

ALLEN & HEATH

ALL RANGES



**LARGE FORMAT
LIVE SOUND MIXERS**



**SMALL FORMAT
LIVE SOUND MIXERS**



DJ PRODUCTS



**SOUND MANAGEMENT
SYSTEMS**

ALLEN & HEATH

Kernick Industrial Estate
Penryn · Cornwall
TR10 9LU · UK

tel: +44 (0)1326 372070

fax: +44 (0)1326 377097

email:

sales@allen-heath.com

website:

www.allen-heath.com

www.glseries.com

Allen & Heath reserve the right to alter any
information supplied in this document or any
other documentation supplied hereafter.

issue - 2 / AP5906



**LARGE FORMAT
LIVE SOUND MIXERS**

ALLEN & HEATH

WORLD CLASS MIXING

REAL WORLD

QUALITY

INNOVATION

A SOUND INVESTMENT

35
35 YEARS OF AUDIO EXCELLENCE
ALLEN & HEATH



For the past 35 years, **ALLEN & HEATH** has been designing professional audio solutions for customers all around the world, supplying to renowned installation companies such as Clair Brothers, international DJ's and clubs like the iconic Ministry of Sound and for high profile venues such as the 2008 Olympic stadium in Beijing.

We are passionate about live sound – any live sound – so we get just as much satisfaction out of providing exactly the right product for the thousands of lower profile jobs as we do for all the elite projects.

Welcome to 'real world' sound engineering.

Whether you run a hire company, or are a sound engineer or contractor for a concert hall, bar, nightclub, festival, house of worship, school, theatre, lecture hall, stadium, museum or TV studio, **ALLEN & HEATH**'s range of live sound mixers has been designed with users in mind. Our mixers are functional, affordable, dependable desks.

ALLEN & HEATH prides itself on listening to users, designing with passion, and delivering superior, cutting-edge products.

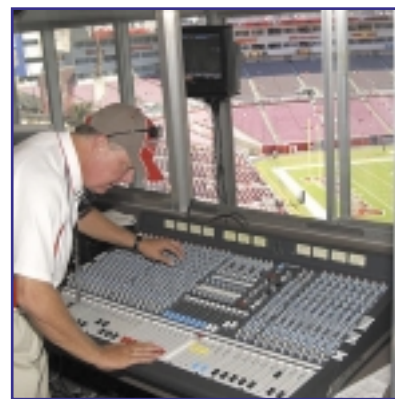

We are focussed on providing the highest sound quality and our mixers are renowned for 'warmth', 'depth' and 'fullness'. We use the best technology and quality components - extruded aluminium frame and steel chassis furnished with vertically-mounted circuit boards secured to the panel with steel nuts - resulting in a build quality that is second to none.

Our R&D team is dedicated and approachable, with decades of live mixing and field support experience, who also happen to be some of the greatest audio engineering minds in the business! They have allowed us to maintain our position at the forefront of audio technology innovation over our 35 years.

When you purchase an **ALLEN & HEATH** console you are investing in outstanding technology that brings together over 35 years of creative and engineering skills that will give you many years of faithful service and exceptional sound quality.

Making great products – it's what makes us tick!

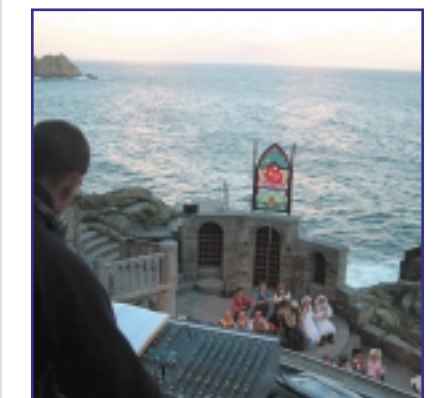
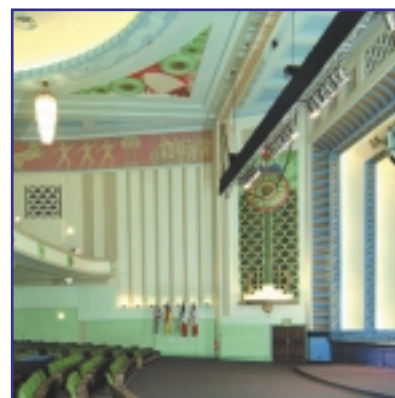
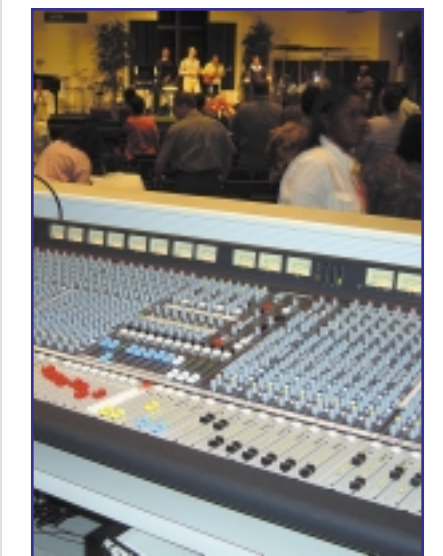
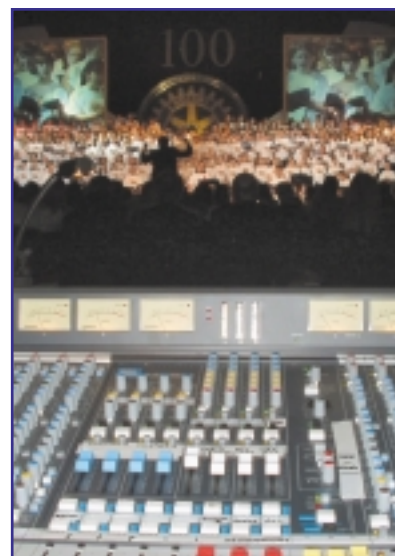

ML OVERVIEW



ML Series VCA live sound consoles embody **ALLEN&HEATH's** mission to make previously exclusive technologies available to people on a real world budget. These mixers have changed the rules for live sound VCA desks, forever raising the professional audio industry's price to performance expectations.

From their intuitive surface layout to their stylish good looks, **ML** consoles have been impeccably designed to provide excellent performance for any live sound situation, whether at front of house or on monitors on tour, performing both jobs in a theatre or house of worship, or providing live facilities in late night clubs – the list of venues where **ALLEN&HEATH ML** consoles have performed day and night over the last few years is endless.

Careful design of the audio circuitry has produced a no-compromise performance which will delight your audiences night after night. **ML Series** mixers offer an I/O capability and feature set that satisfies the latest trends in live sound engineering, in particular the growing number of inputs and outputs for multi-speaker house and monitor systems, demands of stereo in-ear monitoring, 3 speaker LCR imaging, advanced grouping and automation. They are serious, rider-friendly contenders.



VCA's

VCA's on a mixing desk make the engineer's life a lot easier when confronted with mixing multiple sources in a complex sound field. The advantages are many – Stereo and even LCR groups can be controlled using single master faders. Channels can be assigned to more than one VCA group, for example a trumpet to 'Brass', 'All Orchestra' and 'Grand Master' groups. Channel post-fade auxes track the level of the VCA group faders so that the reverb returns stay in proportion to the 'dry' signal in the mix. The VCA group assignments can be managed by the snapshot memory system for automated control. VCA group muting and PAFL control are available too. We believe that VCA's are such a great feature that we've written a book about it! Download your copy from www.allen-heath.com.

Matrix

The matrix is becoming an increasingly important tool in modern multi-task mixing. With ever increasing demand for different output mixes for sound effects, zone and delay speakers, additional monitor mixes, recording, video, broadcast and more, **ML** mixers are provided with a comprehensive matrix fed from the groups, the LCR mix, and an external input. Conveniently positioned away from the live performance controls, the matrix represents a 'mixer within the mixer' to quickly set up the special feeds.



LCR+

The LCR+ system, unique to **ALLEN&HEATH ML Series** mixers, extends signal imaging beyond conventional LR and LCR panning by allowing three-speaker balance and positioning from each channel and group. The system consists of a conventional pan pot plus a blend control, which allow signals to be dialed in to the centre buss – an ideal feature for engineers who want to bring out a signal from the LR mix into a centre cluster or in-fill speaker system. The signal can also be positioned at any single point within the LCR image – just like conventional LCR panning. This function is available from the channels and the audio groups.

Stereo Capability

With the growing demand for stereo 'in ear' monitoring, **ML** mixers allow up to 4 (**ML5000**) true stereo aux mixes to be created. each with separate level and pan controls. With pre/post selection, these are ideal for stereo monitors, recording and balancing between effects sends.

Fully featured dual stereo channels are added to the channel count. This space saving facility enables two stereo sources to be combined into one channel, for example when mixing in effects returns, sound effects and backing track players, or walk-in music with pre-recorded announcement sources. Optional 'B' versions of the **ML5000** and **ML4000** are available, providing 4 additional stereo channels in place of the 4 mono channels next to the existing stereos.



Dual Functionality

ML Series mixers offer full walk-up-and-go functionality at both FOH and stage monitor positions. With no controls redundant in either mode, these feature packed consoles are ideal for multi-function venues and hire companies where they can mix FOH one day, monitors the next, and then monitors from FOH, all without compromise.

On stage, they emulate the classic monitor console providing proper fader control of wedge, stereo in-ear monitors, and even the engineer's local listen wedge. Each mix has fader, insert, full metering, and balanced XLR drive up to +27dBu. Important details such as PFL automatically overriding AFL, the stereo monitoring capability and assignable talkback help the engineer work quickly and stay in control. At front-of-house, the mixer is well equipped with a full set of groups, auxes, matrix, LCR capability, VCA groups, mute groups and snapshot memory automation for dealing with the most challenging stage productions.

Power Supply

All **ML Series** consoles are supplied as standard with the rugged RPS14 linear power supply, which is designed with a built-in combiner for connection to a second supply for backup. As an alternative, the switch-mode MPS14 may be ordered as a no-charge upgrade for those requiring either light weight or high tolerance to input voltage fluctuation.

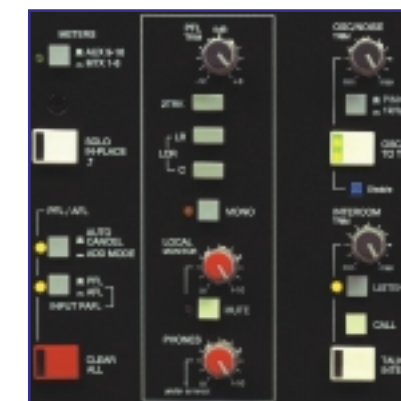

Engineer's Toolbox

Lying at the heart of every **ML Series** console is the 'engineer's toolbox'. This provides a combination of useful facilities to keep the engineer in full control of the audio setup, including status switching, console monitoring, system line-up, communications and automation. An extensive array of metering, including both LED and VU metering of the main outputs and PAFL signals, displays the signal activity of all inputs, busses and outputs. Further tools include an oscillator/pink noise generator, comprehensive talkback system, built-in ClearCom™ compatible intercom using the console's headphone and talkback mic, headphones and local mono/stereo monitoring system, and intelligent PAFL system with some ingenious facilities for quickly auditioning the console signals.

All models include mute groups and an onboard 128 snapshot memory system to store and recall the console mutes and VCA assignment settings, ideal for recalling band setups and show scenes. These can be accessed and archived using the downloadable **ALLEN&HEATH ML Archiver** PC software via MIDI or RS232. The **ML5000** provides convenient front panel control of these memories, as well as advanced features such as channel automation safes for 'on the fly' changes during a live performance, and Solo-in-Place with safes function to listen to the contribution of individual or combinations of sources during sound checking.

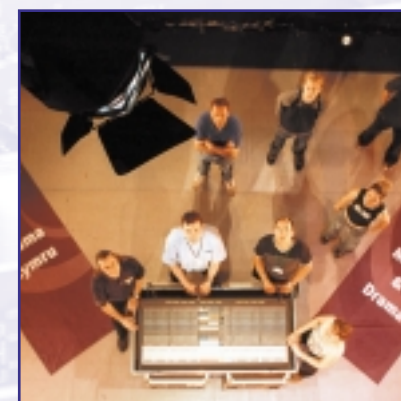
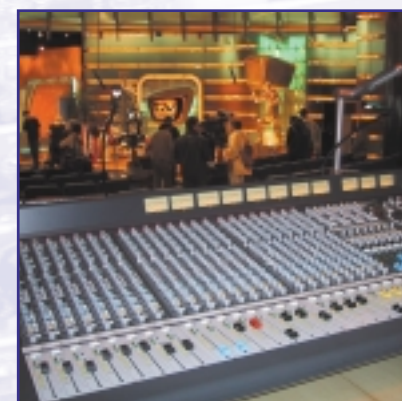
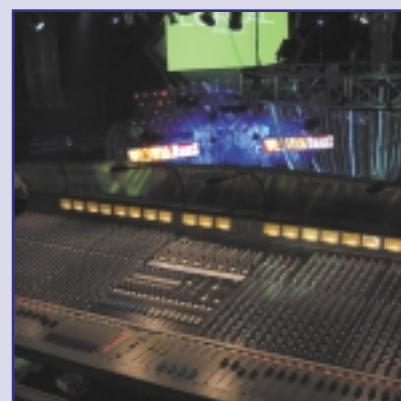

ML 5000

The **ML5000** embodies the professional sound engineer's ideal tool set – a versatile, feature-packed and rider-friendly console, in an intuitive, walk-up-and-go format.

ML5000 is a dual function, LCRplus, 8 group, 16 aux, 12x8 matrix, VCA console. Frame sizes range from 32+4 to 48+4 channels, with sidecar expansion to 96+4 channels. With such exceptional sound quality, it's an engineer's dream!



FEATURES

- ▶ 32+4, 40+4, 48+4, plus up to 2x 24 input sidecars, total 96+4 channels
- ▶ 4 extra dual input stereo channels fitted as standard
- ▶ B option for 4 extra dual stereos in place of mono channels
- ▶ 8 VCA groups with mute and PAFL functions
- ▶ Dual functionality for mixing front-of-house, stage monitors or both
- ▶ Monitor mode provides 16 auxes with pre switching, faders, inserts, mutes, bus and output meters
- ▶ FOH mode provides 8 groups with individual routing and 16 auxes
- ▶ LCRplus panning available from channels and groups.
- ▶ Stereo switching for up to 4 true stereo sends from pairs of auxes
- ▶ 12x8 matrix with inserts and external inputs
- ▶ 8 mute groups
- ▶ 4 band, full sweep EQ with variable Q on midrange
- ▶ Swept 20-400Hz HPF
- ▶ Stereos can mix two balanced sources into one channel, includes L, R L+R mono switching
- ▶ Balanced inserts with separate send and return sockets
- ▶ 128 snapshot memories for recall of VCA assignments and mutes
- ▶ MIDI/RS232 ports for remote archiving and show control
- ▶ **ALLEN & HEATH ML Archiver** software available for PC control of the memories
- ▶ Single press clear or set all mutes or VCA assignments functions
- ▶ Talkback to any of the fader masters, matrix, LR and C
- ▶ ClearCom™ compatible intercom works with console headphones and TB mic
- ▶ Intelligent PAFL system – PFL override AFL for quick multi-mix output/source monitoring
- ▶ Intelligent PAFL system – AFL cancel PFL, all clear, auto-cancel or add modes
- ▶ Intelligent PAFL system – Input PFL or stereo-in-place AFL
- ▶ Intelligent PAFL system – mono or stereo AFL of masters and matrix
- ▶ Solo-in-Place with last solo toggle and channel solo safes
- ▶ Simultaneous LED bar and moving coil VU metering of all main outputs and P/AFL
- ▶ Fader driven engineers listen wedge feed with insert in monitor mode
- ▶ Separate stereo headphones and local monitor control
- ▶ LCR to stereo engineer's monitor capability
- ▶ 1kHz oscillator / pink noise generator
- ▶ Preamp input capability for mic or line up to +30dBu
- ▶ Main, group, aux and matrix outputs on balanced XLR
- ▶ 4-pin XLR lamp sockets – **ALLEN & HEATH** LEDlamp available
- ▶ Uses RPS14 external power supply with built-in combiner for a backup supply
- ▶ Internal aux jumper options for pre-insert, pre/post-EQ, pre/post-mute settings and direct output jumper options for pre/post-fader or to use aux 1 post-fade trim



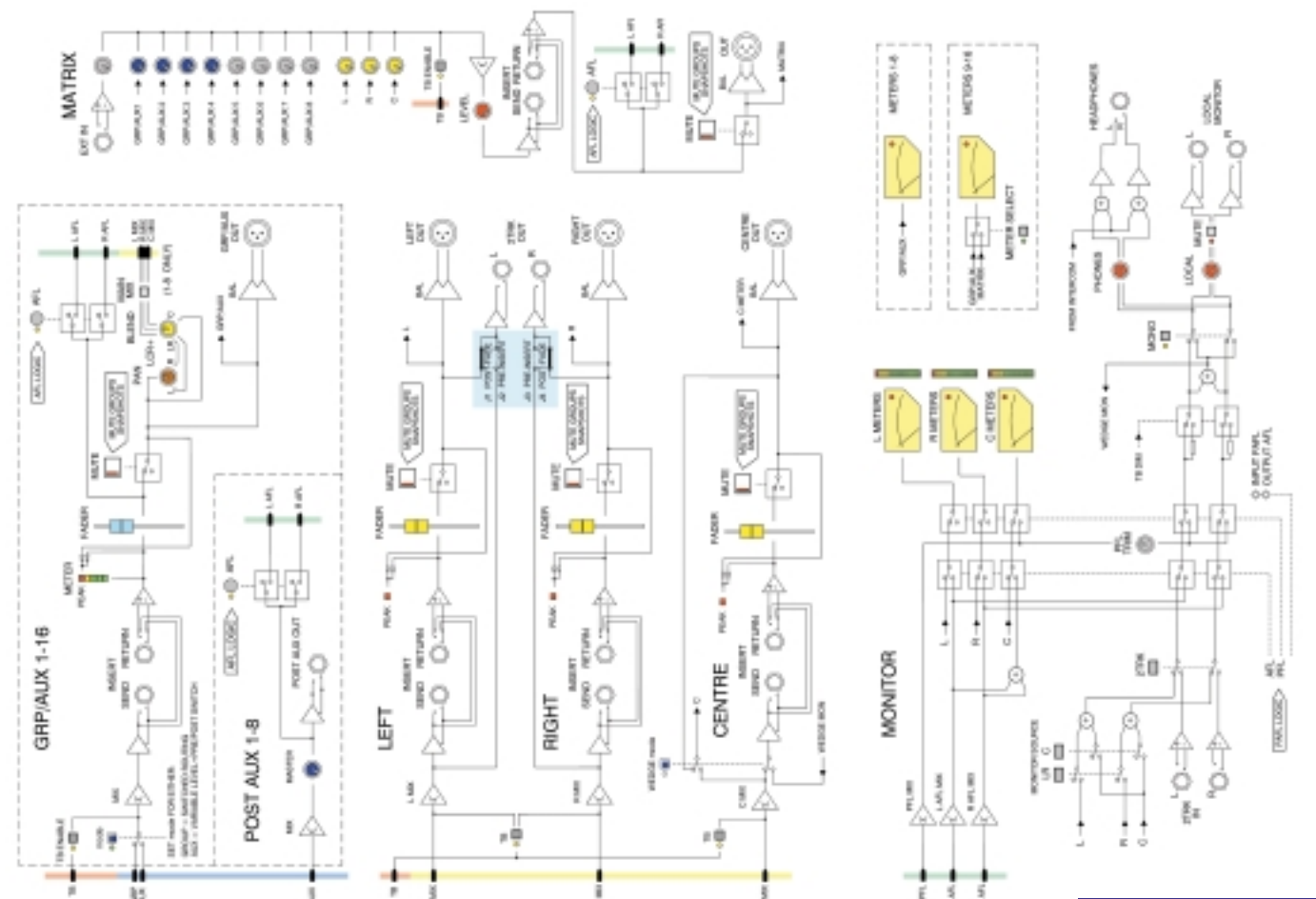

ML5000
System Block Diagram

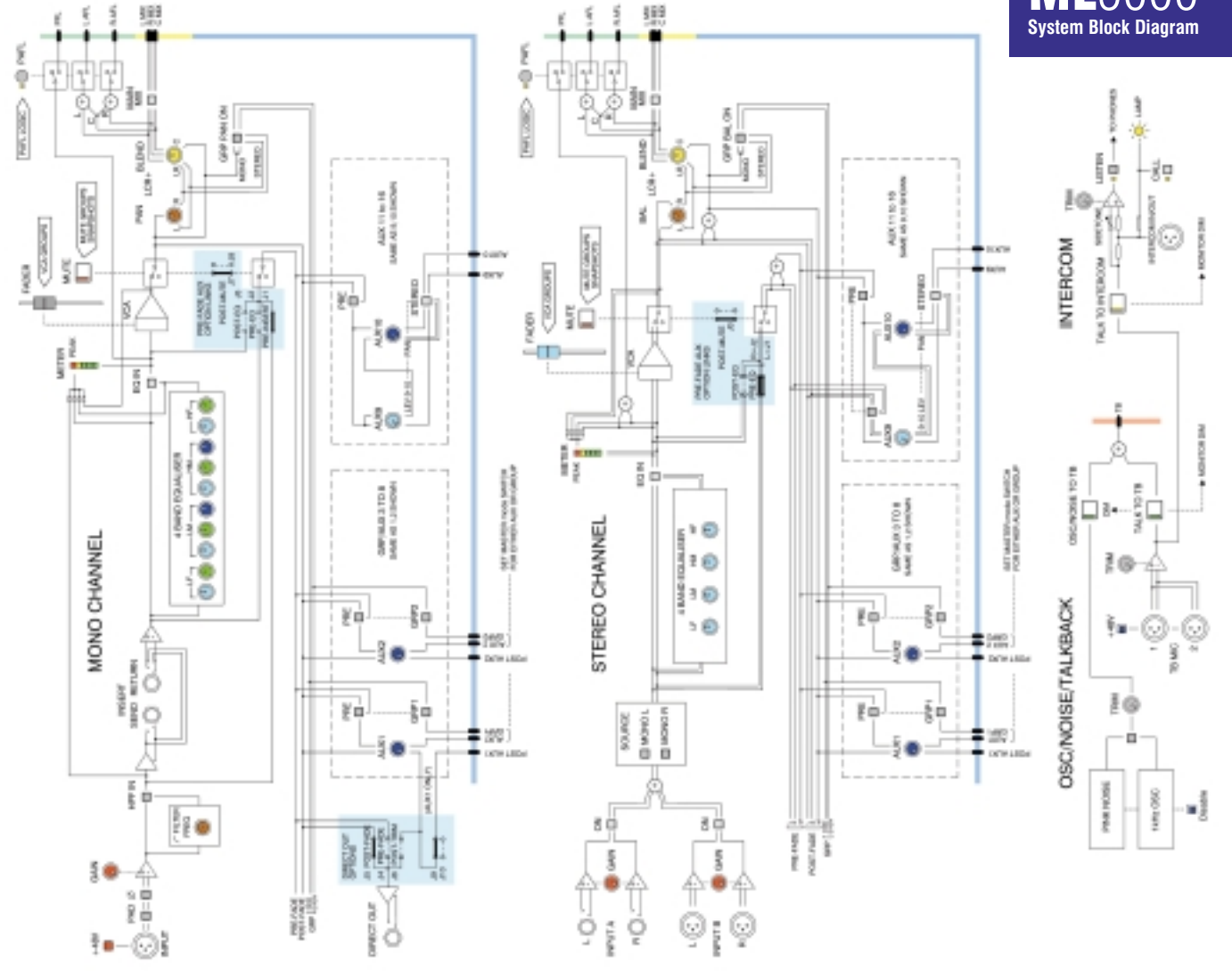

ML 4000

The **ML4000** is the ideal all-purpose solution for install, PA hire and touring applications, handling both front-of-house and stage monitor mixing with ease. With the intuitive layout, and the traditional British EQ and high-definition preamp, getting the right sound couldn't be easier.

ML4000 is a dual function, LCRplus, 8 group, 12 aux, 12x4 matrix, VCA console. Frame sizes range from 24+2 to 48+2 channels, with sidecar expansion to 96+2 channels.



FEATURES

- ▶ 24+2, 32+2, 40+2, 48+2, plus up to 2x 24 input sidecars, total 96+2 channels
- ▶ 2 extra dual input stereo channels fitted as standard
- ▶ B option for 4 extra dual stereos in place of mono channels
- ▶ 8 VCA groups with mute and PAFL functions
- ▶ Dual functionality for mixing front-of-house, stage monitors or both
- ▶ Monitor mode provides 12 auxes with pre switches, faders, inserts, mutes, bus and out meters
- ▶ FOH mode provides 8 groups and 12 auxes
- ▶ LCRplus panning available from channels and groups.
- ▶ Stereo switching for up to 2 true stereo sends from pairs of auxes
- ▶ 12x4 matrix with inserts and external inputs
- ▶ 8 mute groups
- ▶ 4 band, full sweep EQ with switched Q on midrange
- ▶ Swept 20-400Hz HPF
- ▶ Stereos can mix two balanced sources into one channel, includes L, R L+R mono switching
- ▶ Balanced inserts with separate send and return sockets
- ▶ 128 snapshot memories for recall of VCA assignments and mutes via MIDI/RS232
- ▶ **ALLEN & HEATH ML Archiver** software available for PC control of the memories
- ▶ Talkback to any of the fader masters, matrix, LR and C
- ▶ ClearCom™ compatible intercom works with console headphones and TB mic
- ▶ Intelligent PAFL SYSTEM – PFL override AFL for quick multi-mix output/source monitoring
- ▶ Intelligent PAFL system – AFL cancel PFL, all clear, auto-cancel or add modes
- ▶ Intelligent PAFL system – Input PFL or stereo-in-place AFL
- ▶ Intelligent PAFL system – Mono or stereo AFL of masters and matrix
- ▶ Simultaneous LED bar and moving coil VU metering of all main outputs and P/AFL
- ▶ Fader driven engineer's listen wedge feed with insert in monitor mode
- ▶ Separate stereo headphones and local monitor control
- ▶ LCR to stereo engineer's monitor capability
- ▶ 1kHz oscillator / pink noise generator
- ▶ Preamp input capability for mic or line up to +30dBu
- ▶ Main, group, aux and matrix outputs on balanced XLR
- ▶ 4-pin XLR lamp sockets – **ALLEN & HEATH** LEDlamp available
- ▶ Uses external power supply with built-in combiner for redundant backup
- ▶ Internal aux jumper options for pre-insert, pre/post-EQ, pre/post-mute settings



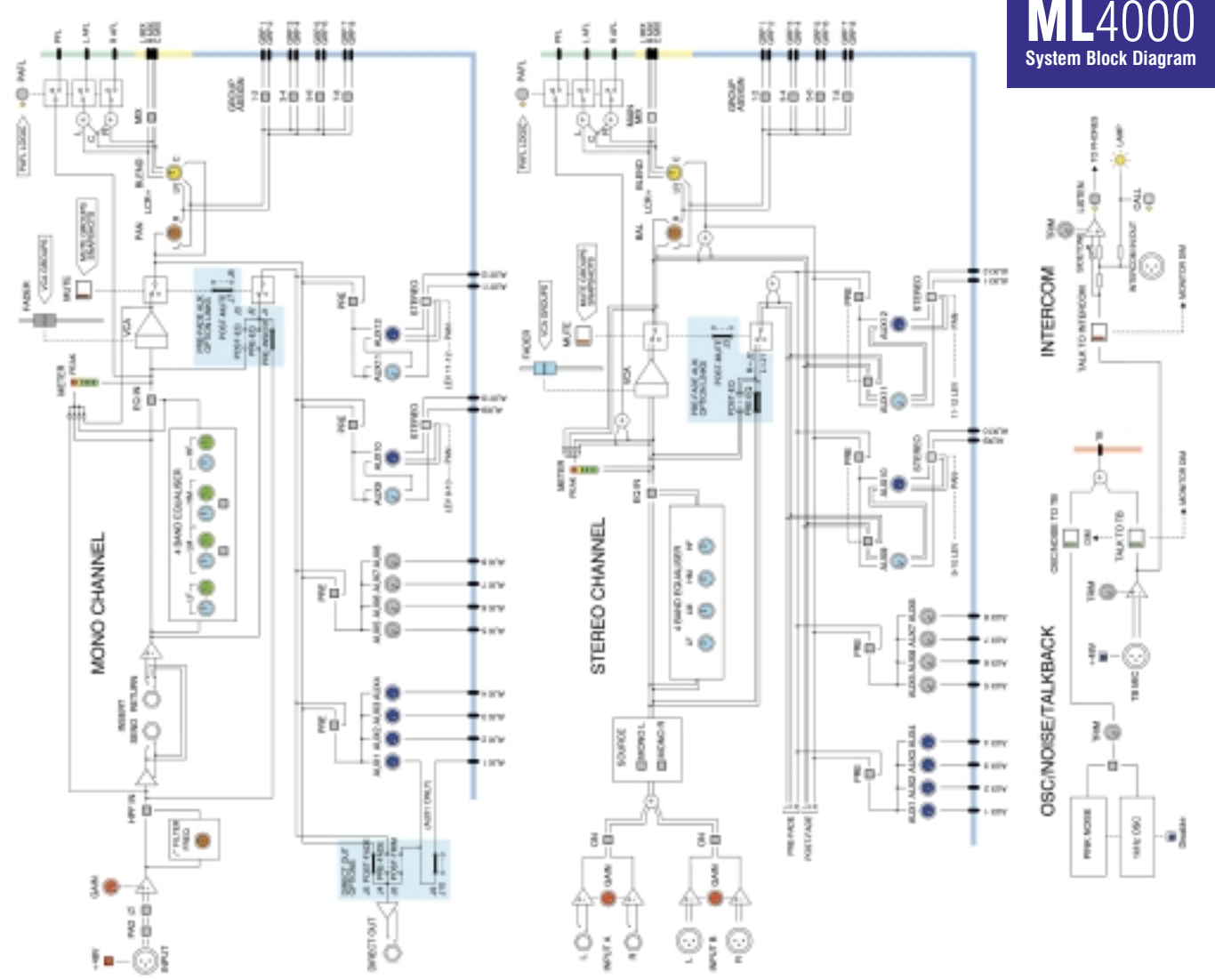
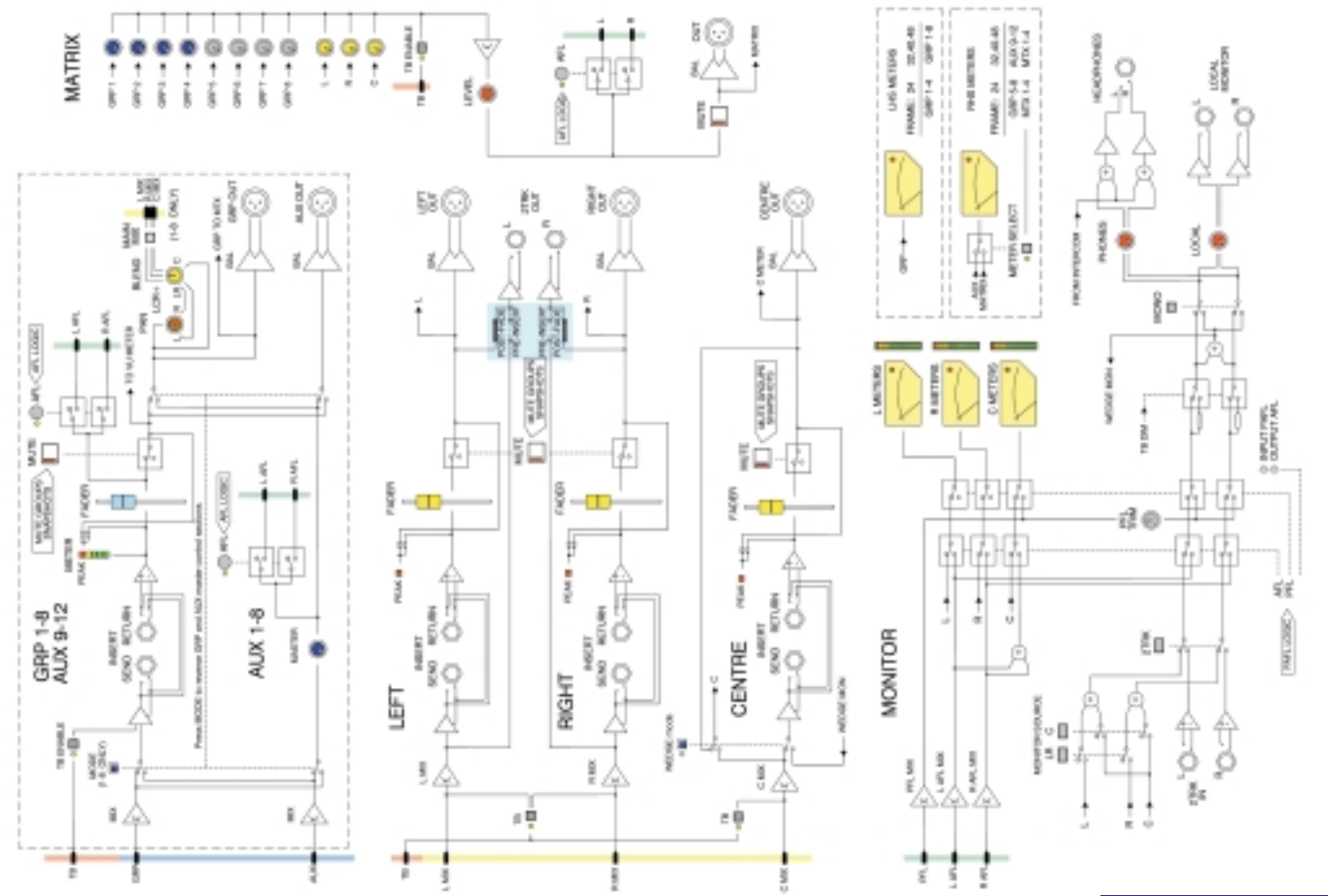

ML4000
System Block Diagram

ML 3000

The most compact VCA mixer available today, but don't let its small size and modest price fool you – this console is packed with all the tools you need for professional live sound mixing. The **ML3000** earns its place in any PA system - the perfect investment!

ML3000 is a dual function, LCRplus, 4 group, 8 aux, 8x4 matrix, VCA console. Frame sizes range from 24+2 to 48+2 channels, with B option for more stereo channels.



FEATURES

- ▶ 24+2, 32+2, 40+2, 48+2 channel frames
- ▶ 2 extra dual input stereo channels fitted as standard
- ▶ B option for 4 extra dual stereo in place of mono channels
- ▶ 8 VCA groups for level control
- ▶ Dual functionality for mixing front-of-house, stage monitors or both
- ▶ Monitor mode provides auxes with faders, inserts, mutes and meters
- ▶ LCRplus panning available from channels and groups
- ▶ 4 audio groups for inserting processors or feeding the matrix
- ▶ 8 aux sends plus aux 7-8 stereo mode for creating a true stereo mix
- ▶ 8x4 matrix with inserts and external inputs
- ▶ 8 mute groups
- ▶ 4 band EQ with swept mid range
- ▶ Swept 20-400Hz HPF
- ▶ Stereos can mix two balanced stereo sources into one channel
- ▶ 128 snapshot memories for MIDI/RS232 recall of VCA assignments and mutes
- ▶ **ALLEN&HEATH ML Archiver** software available for PC control of the memories
- ▶ Talkback to any of the fader masters and LCR outputs
- ▶ PFL override AFL for quick input/output monitoring
- ▶ Fader driven engineers listen wedge feed with insert in monitor mode
- ▶ Simultaneous LED bar and moving coil VU metering of all main outputs and P/AFL
- ▶ Channel meters
- ▶ Separate stereo headphones and local monitor control
- ▶ LCR to stereo engineers monitor capability
- ▶ 1kHz oscillator / pink noise generator
- ▶ Preamp input capability for mic or line up to +30dBu
- ▶ Main, group, aux and matrix outputs on balanced XLR
- ▶ 4-pin XLR lamp sockets – **ALLEN&HEATH** LEDlamp available
- ▶ Uses RPS11 high performance external linear power supply
- ▶ Optional RPSD2 dual supply combiner to link another RPS11 for backup
- ▶ Optional Sys-Link V2 input/output option to link consoles for more channels
- ▶ Internal aux jumper options for pre-insert, pre/post-EQ, pre/post-mute settings
- ▶ Internal direct output jumper options for pre/post-fade or to use aux 1 level trim



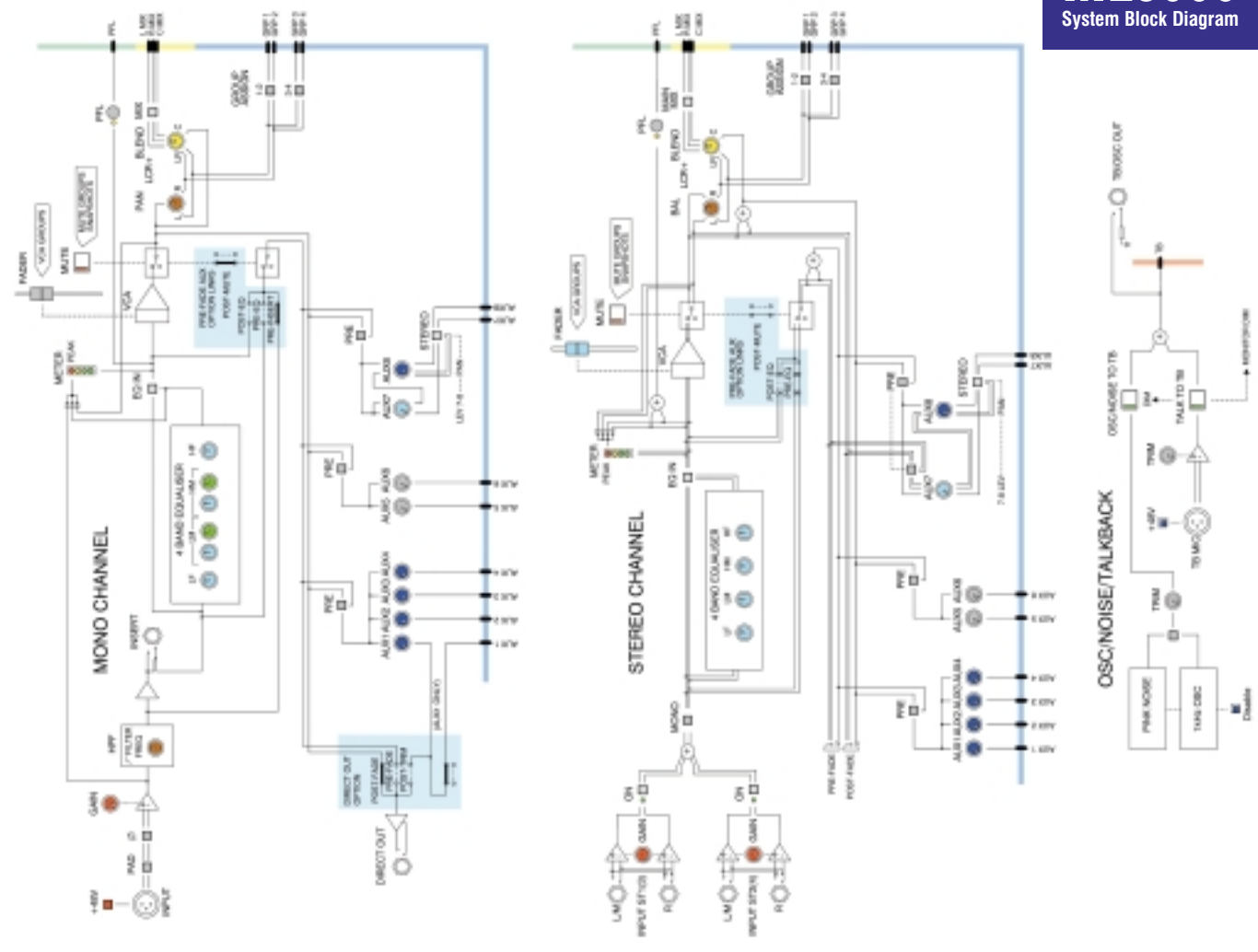
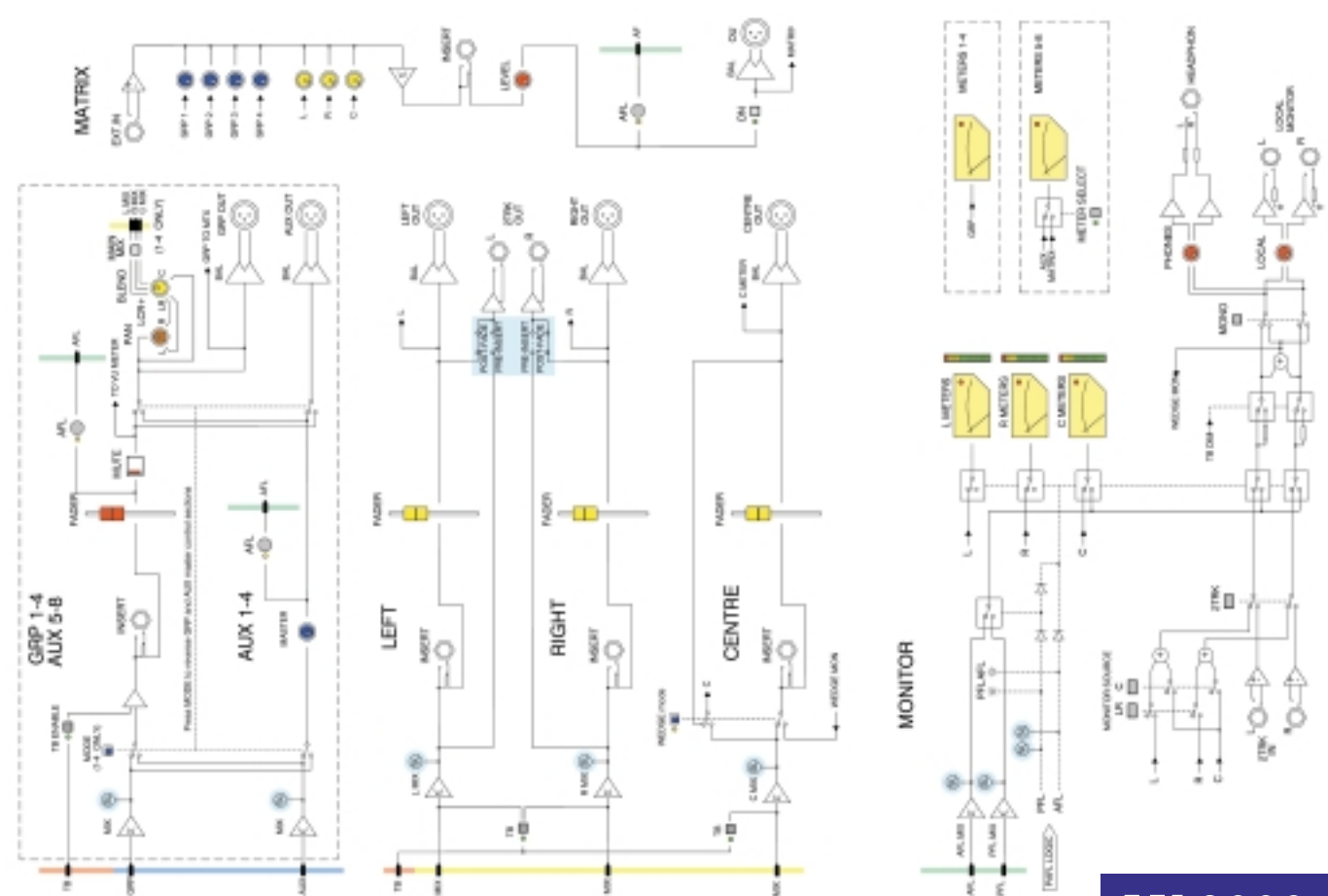

ML3000
System Block Diagram

GL OVERVIEW

For 35 years, **ALLEN&HEATH** has designed truly innovative mixers for the real world and has earned its enviable reputation for superior performance, functionality and build quality. We are proud to present the brand-new **GL Series** of dual function consoles. Providing the benefits of the very best in analogue audio performance and intuitive 'walk up and go' operation, and featuring an enhanced capability for the latest in live sound mixing such as in-ear monitoring, mix-fed subs, ambient recording, engineer's wedge/earpiece monitoring and matrix flexibility, the new **GL Series** retains the rugged, all metal, individual card build for which **ALLEN&HEATH** is renowned. These models benefit from the latest manufacturing methods and audio circuit developments. The **GL Series**: built to perform, built to last.



GL SERIES



Dual Functionality:

As pioneers of dual functionality, we have ensured that every detail of the concept has been carefully implemented in the new **GL Series**, with no controls redundant in either mode. When mixing Front-of-House, the monitors can be set pre-insert as well as pre-EQ, to prevent the house mix EQ and compression affecting the stage mix. Per-channel aux switching means one can mix pre-fade with post-fade sends such as theatre radio mics and sound effects. As a monitor console, the aux masters get faders, inserts, mutes, meters and balanced XLR drive. The Groups and LR mixes are still available to create yet more sends.

Engineer's Toolbox:

There is an abundance of useful tools on all **GL Series** mixers. While the details vary from console to console (check the feature pages), all are equipped with well thought out facilities to help the engineer do a better job. For example, the **GL4800** is equipped with a comprehensive monitoring system, with stereo PFL, PFL trim, PFL override AFL, LED meters on every channel and even the mix busses, additional moving coil VU output meters, local and headphone outputs, and Solo-in-Place. **GL3800** and **GL2800** feature recessed channel pre/post-EQ switches for quick setting of pre-fade aux user preference, 3 headphones outputs (including a small jack socket for ear pieces), a talk latch mode for using a switched handheld talkback mic, oscillator/pink noise generator and extensive metering.



Performance:

Our new mic preamp has an extended 74dB gain range with massive headroom able to deal with the widest range of signals right up to +34dBu. From the new low-noise mix amp through responsive 4 band EQ to the differential balanced +26dBu outputs, every stage has been carefully designed to ensure optimum gain structure, extended dynamic range and the best sonic performance possible.

Third Master Fader:

All **GL Series** consoles have a third master fader. For **GL2400**, this means that the configurable M fader can be used to create an LR sum mono fill, an engineer's monitor wedge feed, or a dedicated centre or sub-bass speaker mix from Aux 6, which means anything can be 'dialed-in' from any channel. On **GL2800**, **GL3800** and **GL4800**, the third fader can be fed from the LR sum, a dedicated mono C mix buss, or both, or become the engineer's monitor wedge feed.

Matrix:

A matrix is included in every new **GL** mixer, a big feature for corporate AV work, specialised recording and broadcast feeds, and personal monitoring. Smart auto-switching of the external inputs allows common mono, stereo or independent sources to be added to the matrix mix, whether adding ambience, general 'starting point' mixes or linking consoles into the same **PA**. The stereo channel mic breakpoints can be cross patched to add room ambience to recording and IEM feeds. Learn more by downloading our guide to matrix mixing from www.glservices.com.



Stereo Channels:

GL Series consoles are equipped with either 2 or 4 full feature stereo channels. The larger format **GL4800** and **GL3800** provide the benefit of ordering options for 4 or 8 stereos in place of mono channels. The compact **GL2400** and **GL2800** provide 2 stereo strips with mic and stereo line inputs on each. Clever switching allows these channels to be used as mic or line inputs. The **GL2800** and **GL3800** add two extra 'short' fader dual stereo channels. Stereo sources such as backing tracks and reverbs can be combined into the strips while the mics are patched elsewhere, for example, to get ambience into a matrix mix, for use with a system calibration microphone, or to use an external phantom powered mic with a video camera. True versatility in a tiny space!

Input / Output Capability:

The **GL Series** provides 4 ranges each with a choice of frame size. In fact, there are no less than 41 models to choose from, and there are still plenty more channel combinations possible by linking consoles using the Sys-Link option. The larger **GLs** provide an optimum 10 auxes and 4 matrix, a powerful set of outputs for creating a manageable combination of mono and stereo mixes. The dedicated stereo aux of the **GL2800** and **GL3800** is perfect for true stereo in-ear, recording and effects mixing, or even dual effects such as balancing a vocal between two different reverb devices.

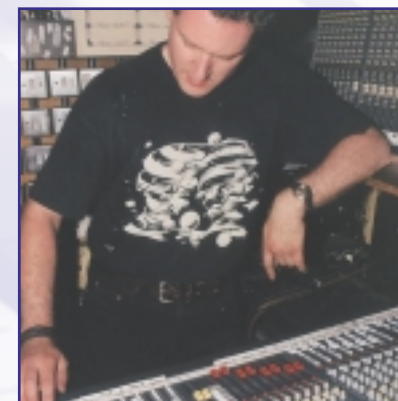

Practical Mixing:

Choosing a console is not just about its number of channels and features. Top of the list is the reassurance that it will continue to perform reliably day after day facing the challenges and unpredictable nature of live sound engineering. These new consoles build on the proven success of the pioneering **ALLEN&HEATH GL Series**. The design has invested in the things that matter – rock solid on-the-road reliability and uncompromising sonic performance able to get the best out of any **PA** system. There are many other considerations too, such as the size and convenience for flight casing and installation, ease of use for the new operator, and the serviceability and technical support. All **ALLEN&HEATH** consoles are designed for the most intuitive layout with logically grouped and colour coded controls, and sensible control positioning to help focus the operator on the job rather than finding the way around the equipment. Even details such as the recessed configuration switches that prevent mistakes during live operation can make a big difference.

The **ALLEN&HEATH** design team have decades of experience being there working with the equipment under pressure, talking to and listening to users both experienced and those just starting out, and following the developing trends in sound engineering.



GL4800

The newest generation of the tried and tested thoroughbred **GL4000**. Flexible and multi-tasking, it is equipped to deal with any number of live sound and recording tasks. Bristling with configurable mode switches and the optimum combination of 10 auxes and 4 matrix, this console can adapt quickly to the toughest sound mixing challenges.

GL4000 is a large format, multi-function, LR, M, 8 group, 10 aux, 11x4 matrix console. Frame sizes range from 24 to 48 channels, with A,B,C,D options for more stereo channels.

A = all mono channels
B = 4 stereos to right of masters
C = 4 stereos on far right side
D = 8 stereos on far right side



FEATURES

- ▶ 24, 32, 40, 48 channel frames
- ▶ A,B,C,D mono/stereo channel options
- ▶ Multi-functionality for FOH/Monitor mixing and live recording
- ▶ LR and M main mixes
- ▶ 8 Audio groups with pan and routing to LR and M
- ▶ 11x4 Matrix
- ▶ 10 Auxiliary sends with faders, inserts and XLR
- ▶ Aux 10 can provide channel direct output pre/post and level trim
- ▶ Group out pre/post switching and level trim for recording
- ▶ Per channel pre/post fader aux switching for unlimited flexibility
- ▶ Second (LR2) output with pre/post fader selection and level trim
- ▶ Output reverse mode to swap aux inserts and XLR with matrix and LR2
- ▶ 2-track replay to LR and monitor
- ▶ Stereo channel line inputs can be assigned independently to LR
- ▶ 4 band, 4 sweep EQ with switched Q on midrange
- ▶ Swept 20-400Hz high pass filters
- ▶ Unique matrix to aux link for quick monitors and grouped effects
- ▶ 128 snapshot memory mute automation with preview and safes functions
- ▶ 8 Mute groups or scenes
- ▶ Solo-in-Place with toggle last and safes
- ▶ Single press clear or set all mutes function
- ▶ Mutes on all fader masters
- ▶ Meters on all buses to warn of mix overload
- ▶ Simultaneous metering of the groups, LRM and auxes
- ▶ Integral LED-illuminated moving coil VU meterpod
- ▶ Simultaneous LED bar and moving coil VU monitor metering
- ▶ Mono/stereo PFL with trim
- ▶ PFL override AFL for logical input/output monitoring
- ▶ Engineer's wedge fader control in monitor mode
- ▶ Separate headphones and local outputs
- ▶ Talkback to LR, M, groups, matrix, and to each aux
- ▶ Electronically balanced XLR outputs with +26dBu drive capability
- ▶ Preamp input capability for mic or line up to +34dBu
- ▶ Ultra low noise mix head amp design
- ▶ Balanced inserts with separate send and return sockets
- ▶ 100mm, premium grade dual rail faders as used on the top-of-the-range ML Series
- ▶ 4-pin XLR lamp sockets – **ALLEN & HEATH** LEDlamp available
- ▶ Individual circuit card assembly with nutted pots
- ▶ Uses RPS11 high performance external linear power supply
- ▶ Built-in combiner for redundant backup power supply
- ▶ Sys-Link V2 input linking option for adding a slave console



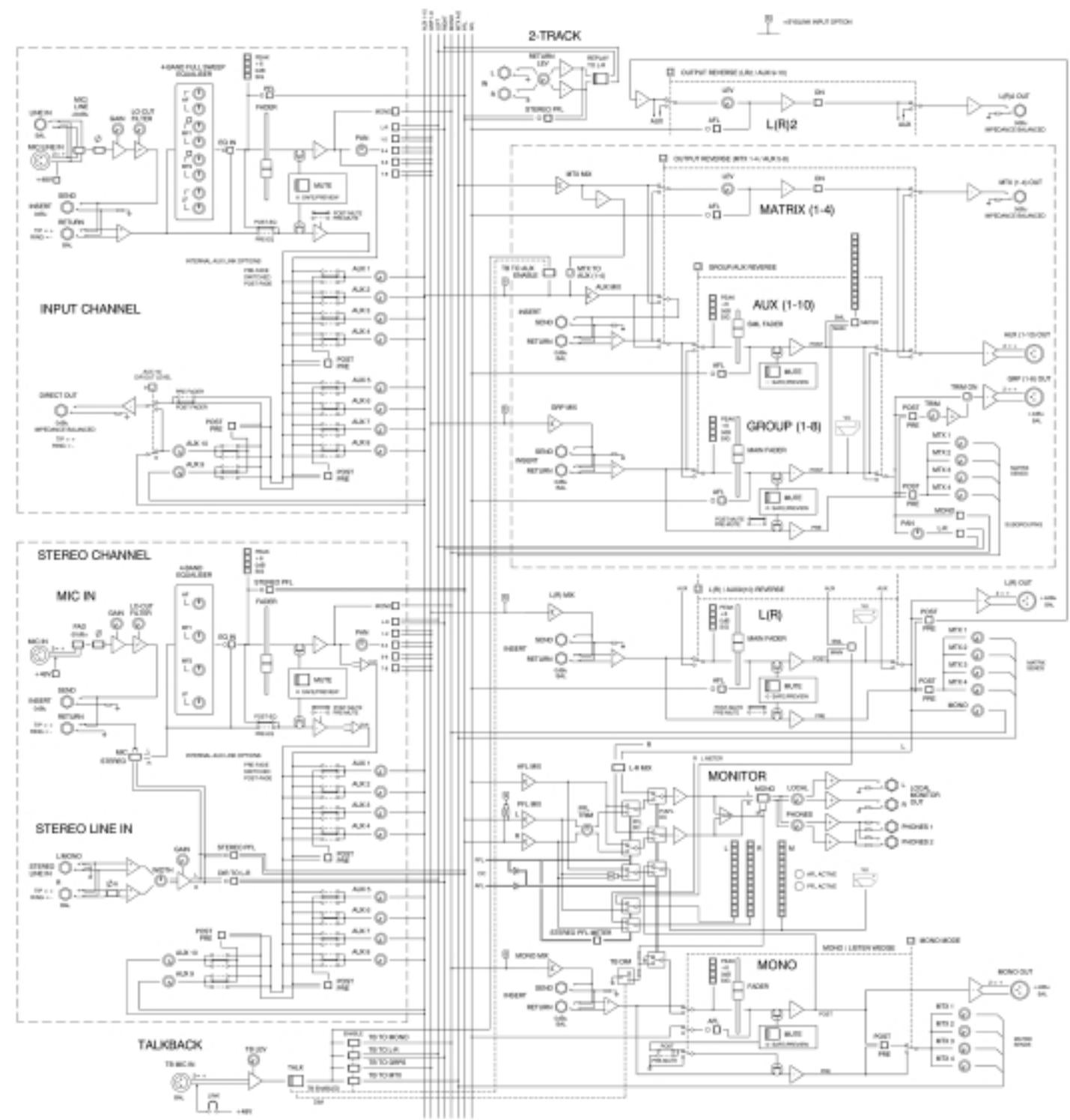

GL4800
System Block Diagram

GL 3800

Whether mixing FOH, monitors or both, recording live, installed in a busy venue, out on the road touring, or earning its keep in rental stock, the **GL3800** provides the perfect solution. This great sounding, well featured console has a familiar, walk-up-and-go layout and responsive feel giving the engineer the very best of analogue console engineering.

GL3800 is a large format, dual function, LR, M, 8 group, 10 aux, 12x4 matrix console. Frame sizes range from 24 to 48 channels, with A,B,C,D options for more stereo channels.

A = all mono channels
B = 4 stereos to right of masters
C = 4 stereos on far right side
D = 8 stereos on far right side



FEATURES

- 24, 32, 40, and 48 channel frames
- A,B,C,D mono/stereo channel options
- LR and M main mixes
- 8 Audio groups with pan and routing to LR and M
- 10 Auxes including a dedicated stereo send with level and pan controls
- 2 multi-function stereo channels each with mic and stereo line inputs
- 2 extra dual stereos provide 4 summed or independent stereo returns
- Fully featured 12x4 Matrix
- Proper dual functionality for front-of-house, monitor mixing, or both
- Recording capable with channel direct outputs
- M can be used for centre/sub mix, LR mono sum, or engineers wedge
- Matrix external inputs with level trims and common input capability
- Stereo channel mic inputs can cross patch into matrix for ambience feed
- Responsive 4 band, 2 sweep EQ
- 100Hz channel high pass filters
- Individual phantom power and polarity switching
- Integral meterpod with 11 LED-illuminated, moving coil VU meters
- Wide angle LED channel and master meters
- Dedicated stereo monitor meters
- Per channel pre/post fader aux switching for full flexibility
- Front panel pre/post-EQ switches for user preference
- Mutes on all fader masters
- 100mm premium grade dual rail faders as used on the top-of-the-range ML Series
- Assignable talkback to all outputs, includes a talk switch latch mode
- 1kHz oscillator / pink noise generator with patchable external output
- 2-track monitoring and replay to LR
- 3 headphones/earpiece sockets and local monitor outputs
- Electronically balanced XLR outputs with +26dBu drive capability
- Preamp 74dB range with +34dBu input capability for mic or line
- Ultra low noise mix head amp design
- Uses RPS11 high performance, external linear power supply
- Built-in combiner for redundant backup supply
- Individual circuit card assembly with nutted pots
- Sys-Link V2 console input/output linking option
- 4-pin XLR lamp sockets – **ALLEN & HEATH** LED lamp available



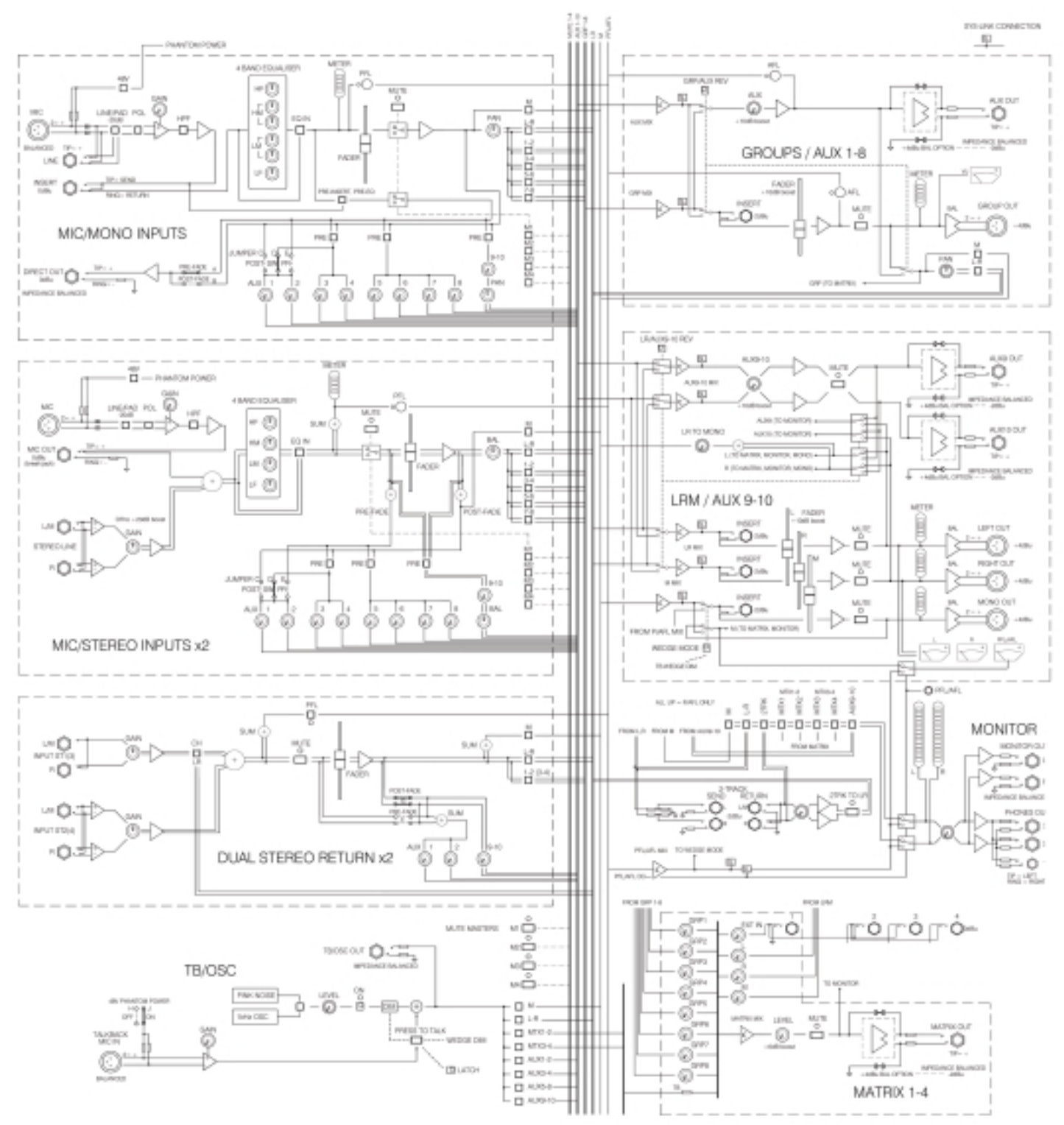

GL3800
System Block Diagram

GL 2800

A brand new dual function mixer derived from the classic **GL Series**, offering a similar well thought out feature set to the larger **GL3800**, this very professional yet affordable console is built into a rugged, small footprint chassis ideal for flight casing and venue installation where space is tight. The **GL2800**, capable, intuitive and comfortable in the hands of any engineer.

GL2800 is a compact, dual function, LR, M, 8 group, 10 aux, 12x4 matrix console. Frame sizes ranges from 24 to 56 channels including 2 stereo channels.



FEATURES

- ▶ 24, 32, 40, 48 and 56 channel frames
- ▶ LR and M main mixes
- ▶ 8 Audio groups with pan and routing to LR and M
- ▶ 10 Auxes including a dedicated stereo send
- ▶ 2 multifunction stereo channels each with mic and stereo line inputs
- ▶ 2 extra dual stereos provide 4 summed or independent stereo returns
- ▶ Fully featured 12x4 Matrix
- ▶ Proper dual functionality for FOH/Monitor mixing
- ▶ Recording capable with channel direct outputs
- ▶ M can be used for centre/sub mix, LR mono sum, or engineers wedge
- ▶ Matrix external inputs with level trims and common input capability
- ▶ Stereo channel mic inputs can cross patch into matrix for ambience feed
- ▶ Responsive 4 band, 2 sweep EQ
- ▶ 100Hz channel high pass filters
- ▶ Individual phantom power and polarity switching
- ▶ Wide angle channel and master meters
- ▶ Dedicated stereo monitor meters
- ▶ Per channel pre/post fader aux switching for full flexibility
- ▶ Internal jumper plugs for pre/post-EQ aux, direct out and other options
- ▶ Mutes on all fader masters
- ▶ Assignable talkback to all outputs, includes a talk switch latch mode
- ▶ 1kHz oscillator / pink noise generator with patchable external output
- ▶ 2-track monitoring and replay to LR
- ▶ 3 headphones/earpiece sockets and local monitor outputs
- ▶ Electronically balanced XLR outputs with +26dBu drive capability
- ▶ Preamp 74dB range with +34dBu input capability for mic or line
- ▶ Ultra low noise mix head amp design
- ▶ Uses RPS11 high performance external linear power supply
- ▶ Built-in combiner for redundant backup supply
- ▶ Individual circuit card assembly with nitted pots
- ▶ Sys-Link V2 console input/output linking option
- ▶ 4-pin XLR lamp sockets – **ALLEN&HEATH** LEDlamp available



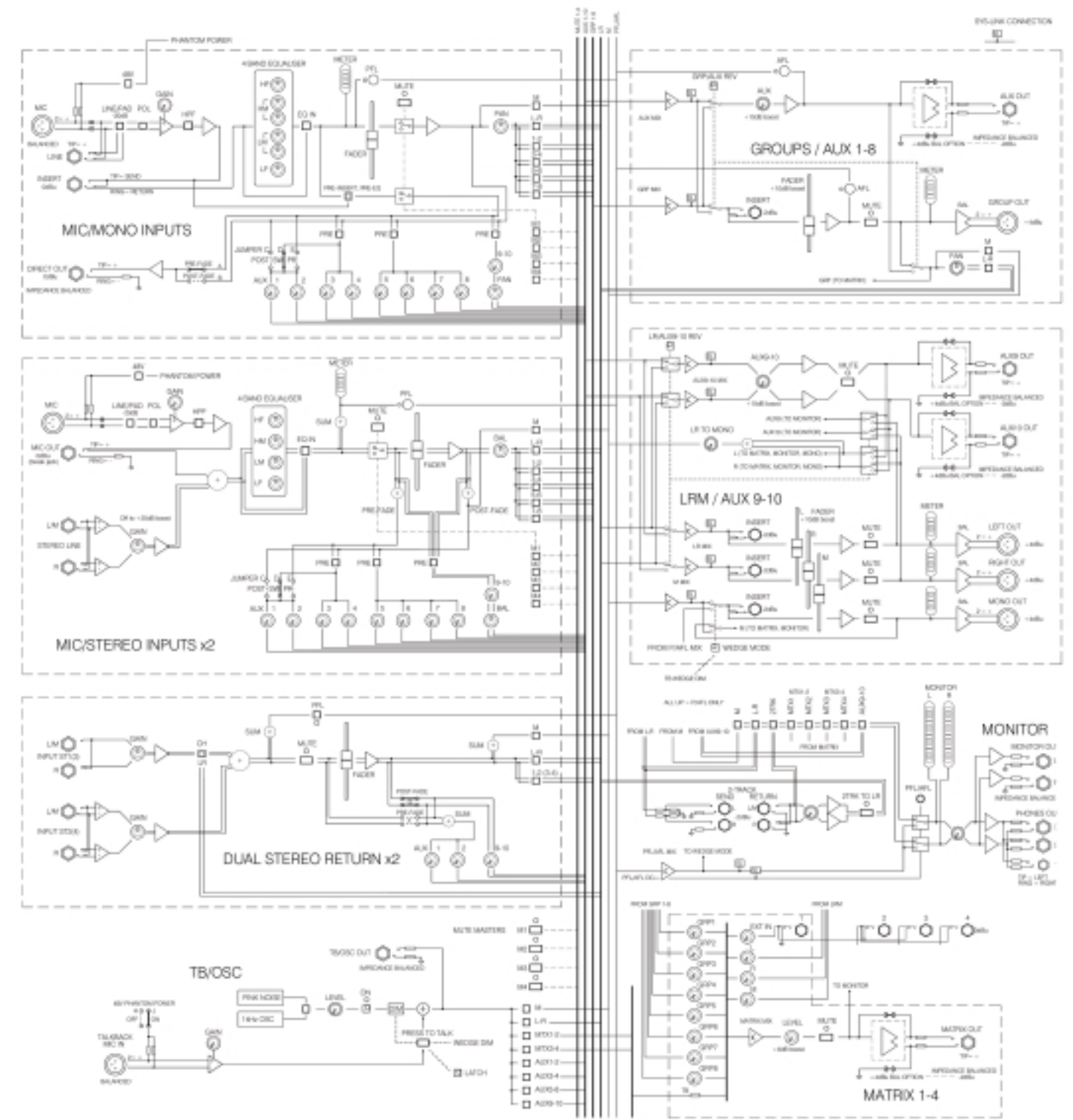

GL 2400

The **GL2400** is the latest version of the highly successful 4 group dual-function **GL2400**. Designed for the latest in modern engineering techniques, every detail in this uniquely capable small footprint mixer has been carefully thought out to provide the very best mixing experience.

GL2400 is a compact, dual function, LR, Mono sum, 4 group, 6 aux, 7x4 matrix console. Frame sizes range from 16 to 40 channels including 2 dual stereo channels.



FEATURES

- ▶ 16, 24, 32, 40 channel frames
- ▶ LR and M main outputs
- ▶ 4 Audio groups with pan control
- ▶ 6 Auxiliary sends with per-channel pre/post fader switching
- ▶ 2 stereo channels each with mic and dual stereo line inputs
- ▶ 7x4 Matrix
- ▶ Proper dual functionality for FOH and/or Monitor mixing
- ▶ M can be configured as LR sum, wedge, or aux-fed sub or C master
- ▶ Recording capable with channel direct outputs
- ▶ Matrix external inputs with level trims and common input capability
- ▶ Stereo channel line inputs can be independently routed to LR
- ▶ Stereo channel mic input breakpoints for cross patching into matrix
- ▶ Responsive 4 band, 2 sweep EQ
- ▶ 100Hz high pass filters
- ▶ Individual phantom power and polarity switching
- ▶ Dedicated channel, master and stereo monitor meters
- ▶ Internal jumper plugs for pre/post-EQ aux, direct out and other options
- ▶ Mutes, meters and AFL on all fader masters
- ▶ Assignable talkback
- ▶ 1kHz oscillator and pink noise generator
- ▶ 2-track monitoring and replay to LR
- ▶ Headphones and local monitor outputs
- ▶ Electronically balanced XLR outputs with +26dBu drive capability
- ▶ Preamp 74dB range with +34dBu input capability for mic or line
- ▶ Ultra low noise mix head amp design
- ▶ Internal power supply with socket for MPS12 backup supply (16 to 32 channel models)
- ▶ External RPS11 power supply and socket for another RPS11 as backup (40 channel model)
- ▶ 100mm dust protected faders
- ▶ Individual circuit card assembly with nipped pots
- ▶ Sys-Link V2 console input/output linking option
- ▶ 4-pin XLR lamp sockets – **ALLEN&HEATH** LEDlamp available



GL2400

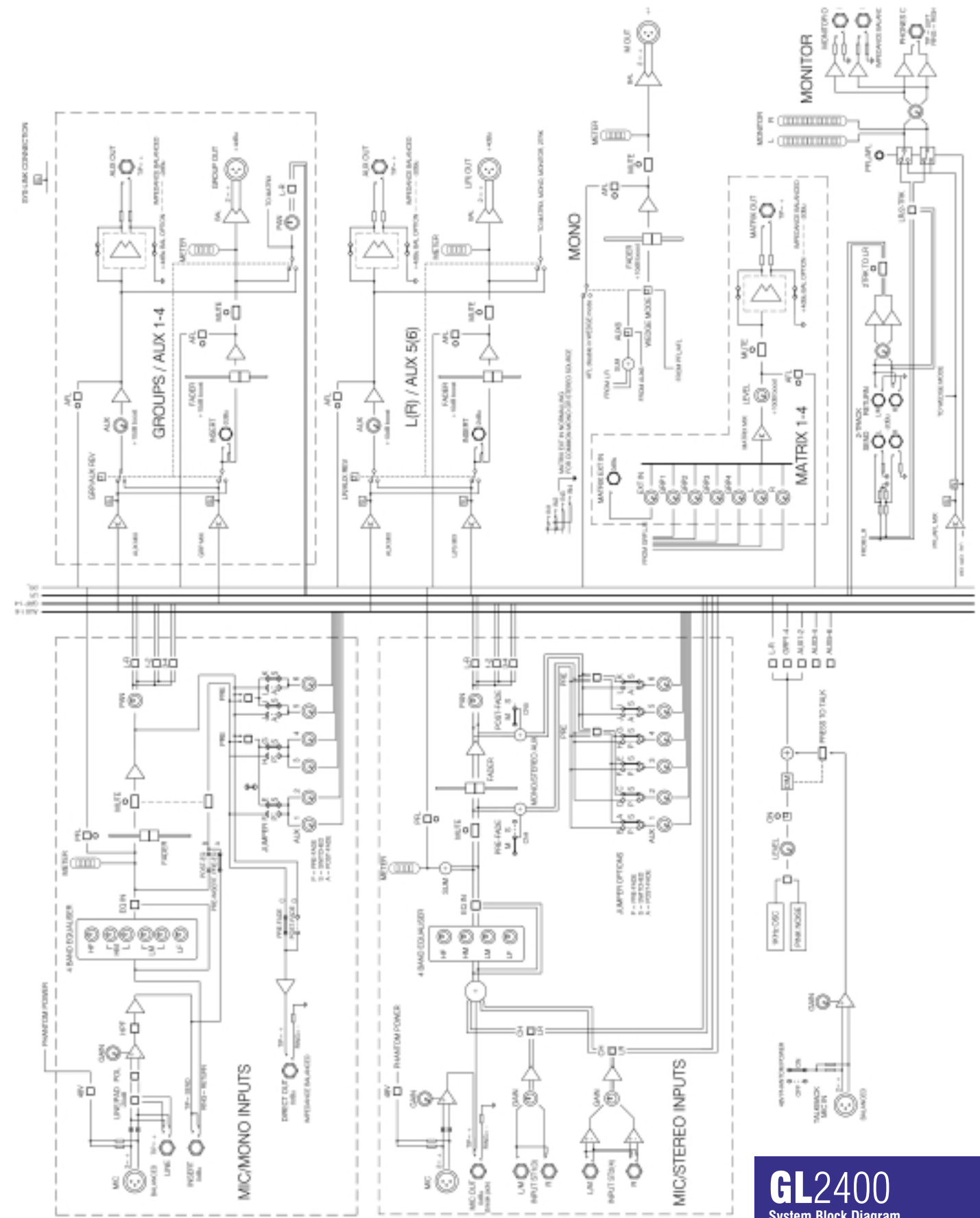

GL2400
System Block Diagram

ML Accessories

SIDE CAR expansion - ML4000

The **ML4000-24SC** is a compact stand-alone unit providing 24 channels with the same input and fader modules as the main console. It is independently powered and connects to the main console using a 9-way logic and two 37-way audio link cables



SIDE CAR expansion - ML5000

The **ML5000-24SC** is a compact stand-alone unit providing 24 channels with the same input and fader modules as the main console. It is independently powered and connects to the main console using a 9-way logic and two 37-way audio link cables



POWER SUPPLY - ML5000 & ML4000

RPS14 is a rugged slimline 2U rack-mount power supply which is provided with **ML4000**. Full protection and thermal sensing fan cooling is provided. It has a built-in combiner for connection to a second supply for backup. It includes two heavy duty DC connectors for plugging to the console and linking in a redundant supply



POWER SUPPLY - ML3000

The RPS11 is a rugged linear 300W 3U rack-mount power supply with DC cable. A second RPS11 can be connected through the RPSD2 Auto-Switching PSU, which monitors the console's power supply and allows silent switching between the two supplies



DUST COVER

A nylon cover that comes in various sizes, tailored to fit the **ML's** differing frame dimensions



LED LAMP

ALLEN HEATH also manufactures LEDlamp, an 18" 4 pin XLR gooseneck console lamp containing a built-in thumbwheel dimmer. The stylish lamp replaces traditional filament console lamps with more user friendly cool white light, and has the additional advantages of lower heat discharge and longer life

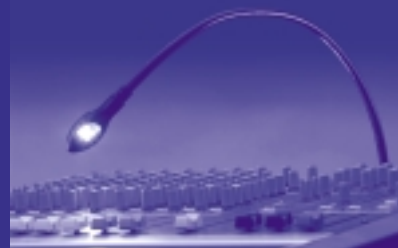

SYS-LINK - ML3000

The **SYS-LINK V2** option allows the **ML3000** console to be easily linked to other **ALLEN HEATH** consoles to expand the number of channels in the mix. Fitting requires the removal of connector blanking plates and the installation of two internal circuit cards

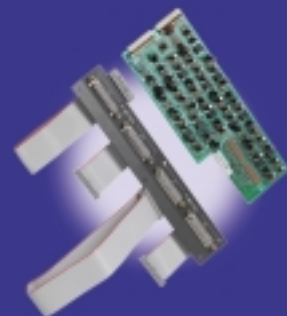

SOFTWARE

ML Archiver software is a Windows application that runs on a PC connected to your console. It lets you access the 128 onboard snapshots, save the console settings and snapshot memories to a disk file, and is used to archive settings as a backup or for future recall



Accessories GL

POWER SUPPLY (back-up) - GL2400-16, 24 & 32

The **MPS12** is a back-up power supply which connects via an internal socket to the existing built-in power supply.



POWER SUPPLY - GL4800, GL3800, GL2800, GL2400-40

The **RPS11** is a rugged linear 300W 3U rack-mount power supply with DC cable. A second **RPS11** can be connected through the **RPSD2** Auto-Switching PSU, which monitors the console's power supply and allows the backup PSU to take over in the event of a fault occurring



DUST COVER - GL4800, GL3800

A nylon cover that comes in various sizes, tailored to fit the **GL4000's** differing frame dimensions

LED LAMP

ALLEN HEATH also manufactures LEDlamp, an 18" 4 pin XLR gooseneck console lamp containing a built-in thumbwheel dimmer. The stylish lamp replaces traditional filament console lamps with more user friendly cool white light, and has the additional advantages of lower heat discharge and longer life



SYS-LINK - (all GL Series)

The **Sys-Link V2** option allows the **GL4000** console to be easily linked to other **ALLEN HEATH** consoles to expand the number of channels in the mix. Fitting requires the removal of connector blanking plates and the installation of two internal circuit cards



SPECIFICATIONS

MECHANICAL SPECIFICATIONS

ML Consoles	A mm(*)	B mm(*)	C mm(*)	D mm(*)	Weight kg(lb)
ML3000-24	252 (10)	640 (25)	110 (4)	1141 (45)	30 (66)
ML3000-32	252 (10)	640 (25)	110 (4)	1396 (55)	40 (88)
ML3000-40	252 (10)	640 (25)	110 (4)	1651 (65)	50 (110)
ML3000-48	252 (10)	640 (25)	110 (4)	1906 (75)	60 (132)
ML4000-24	282 (11)	781 (31)	130 (5)	1196 (47)	53 (116)
ML4000-32	282 (11)	781 (31)	130 (5)	1451 (57)	65 (143)
ML4000-40	282 (11)	781 (31)	130 (5)	1706 (67)	75 (165)
ML4000-48	282 (11)	781 (31)	130 (5)	1961 (77)	87 (192)
ML5000-32	298 (12)	872 (34)	130 (5)	1596 (63)	84 (185)
ML5000-40	298 (12)	872 (34)	130 (5)	1851 (73)	96 (211)
ML5000-48	298 (12)	872 (34)	130 (5)	2106 (83)	110 (242)

GL Consoles	A mm(*)	B mm(*)	C mm(*)	D mm(*)	Weight kg(lb)
GL2400-416	150 (6)	560 (22)	57 (2)	609 (24)	17 (36)
GL2400-424	150 (6)	560 (22)	57 (2)	817 (32)	22 (47)
GL2400-432	150 (6)	560 (22)	57 (2)	1025 (40)	27 (58)
GL2400-440	150 (6)	560 (22)	57 (2)	1233 (49)	32 (69)
GL2800-824	170 (7)	650 (26)	62 (2)	944 (37)	29 (64)
GL2800-832	170 (7)	650 (26)	62 (2)	1171 (46)	35 (77)
GL2800-840	170 (7)	650 (26)	62 (2)	1398 (55)	41 (90)
GL2800-848	170 (7)	650 (26)	62 (2)	1625 (64)	47 (103)
GL2800-856	170 (7)	650 (26)	62 (2)	1852 (73)	53 (117)

GL Consoles	A mm(*)	B mm(*)	C mm(*)	D mm(*)	Weight kg(lb)
GL3800-824	275 (11)	691 (27)	78 (3)	1026 (40)	33 (73)
GL3800-832	275 (11)	691 (27)	78 (3)	1281 (50)	42 (92)
GL3800-840	275 (11)	691 (27)	78 (3)	1536 (60)	51 (112)
GL3800-848	275 (11)	691 (27)	78 (3)	1791 (71)	60 (132)
GL4800-824	285 (11)	748 (29)	75 (3)	1166 (46)	47 (103)
GL4800-832	285 (11)	748 (29)	75 (3)	1421 (56)	57 (125)
GL4800-840	285 (11)	748 (29)	75 (3)	1676 (66)	67 (147)
GL4800-848	285 (11)	748 (29)	75 (3)	1931 (76)	77 (169)

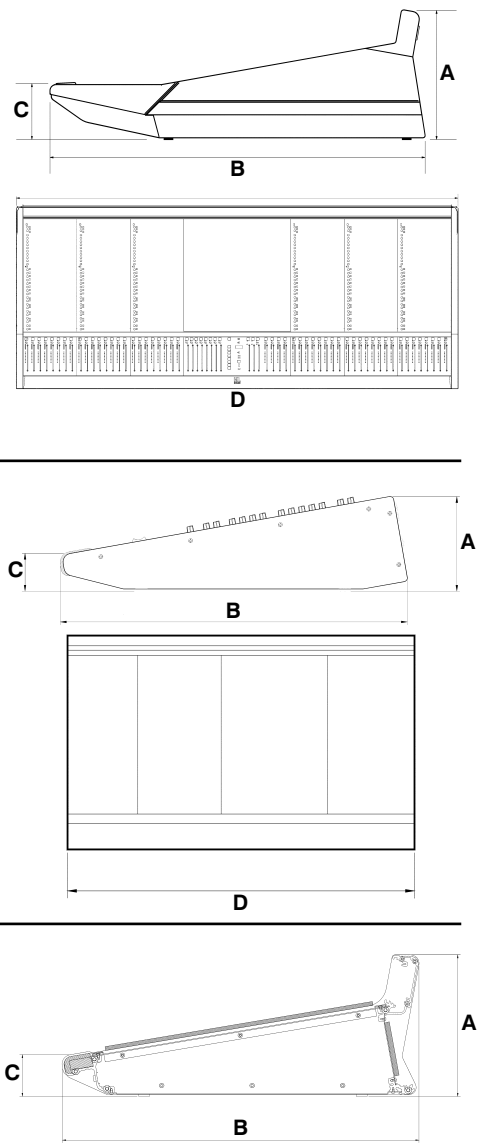

CONNECTIONS

XLR Inputs	Female	Pin2 = +ve polarity	Pin3 = -ve polarity	Pin1 = ground	Chassis = chassis
XLR Outputs	Male	Pin2 = +ve polarity	Pin3 = -ve polarity	Pin1 = ground	Chassis = chassis
1/4" TRS Jacks					
Balanced Input, Insert Return	TRS	Tip = +ve polarity	Ring = -ve polarity	sleeve = ground/chassis	
Balanced Output, Insert Send	TRS	Tip = +ve polarity	Ring = -ve polarity	sleeve = ground/chassis	
Insert (unbalanced)	TRS	Tip = send signal	Ring = return signal	sleeve = ground/chassis	
Unbalanced Input	TRS	Tip = signal	Ring = ground	sleeve = ground/chassis	
RCA Phono	Socket	Tip = signal		Outer = ground/chassis	

TECHNICAL SPECIFICATIONS

	ML5000	ML4000	ML3000	GL4800	GL3800	GL2800	GL2400
OPERATING LEVELS							
Channels	0dBu, +21dB Headroom	0dBu, +21dB Headroom	0dBu, +21dB Headroom	0dBu, +20dB Headroom	0dBu, +20dB Headroom	0dBu, +20dB Headroom	0dBu, +20dB Headroom
Mix	+23dBu	+23dBu	+23dBu	+4dBu	+4dBu	+4dBu	+4dBu
Main Outputs	-60 to +10dBu	-60 to +10dBu	-60 to +10dBu	-60 to +14dBu	-60 to +14dBu	-60 to +14dBu	-60 to +14dBu
Maximum output	+0/-0.5dB	+0/-0.5dB	+0/-0.5dB	+0/-1dB	+0/-0.5dB	+0/-0.5dB	+0/-0.5dB
Mic Pre-Amp Sensitivity	<0.01%	<0.01%	<0.01%	<0.006%	<0.003%	<0.003%	<0.004%
FREQUENCY RESPONSE (20Hz-30kHz)							
Mic to Main output (+40 dB)	>80dB	>80dB	>80dB	>80dB	>85dB	>85dB	>80dB
Line to Main output (0dB)	>50dB	>50dB	>50dB	>55dB	>55dB	>55dB	>55dB
Line to Main output (0dB)	<-100dB	<-95dB	<-95dB	<-100dB	<-97dB	<-97dB	<-93dB
THD + Noise (mic in +40dB gain)	<-90dB	<-90dB	<-90dB	<-85dB	<-88dB	<-88dB	<-94dB
THD + Noise (line in 0dB gain)	<-95dB	<-90dB	<-90dB	<-87dB	<-91dB	<-91dB	<-90dB
COMMON MODE REJECTION @1kHz	<-84dB (84dB S/N)	<-82dB (82dB S/N)	<-82dB (82dB S/N)	<-82dB (86dB S/N)	<-86dB (90dB S/N)	<-86dB (90dB S/N)	<-86dB (90dB S/N)
Mic Input +40dB gain	2k ohms	2k ohms	2k ohms	2k ohms	2k ohms	2k ohms	2k ohms
Mic Input with Pad 0dB gain	>20k ohms	>10k ohms	>10k ohms	>10k ohms	>10k ohms	>10k ohms	>10k ohms
Adjacent Channel Mute Shutoff	<75 ohms	<75 ohms	<75 ohms	<75 ohms	<75 ohms	<75 ohms	<75 ohms
Fader Shutoff	+/- 15dB	+/- 15dB	+/- 15dB	+/- 15dB	+/- 15dB	+/- 15dB	+/- 15dB
NOISE PERFORMANCE (22Hz-22kHz unweighted)							
Mic EIN with 150ohm source	Shell 20Hz - 200Hz	Shell 20Hz - 200Hz	Shell 20Hz - 200Hz	Shell 20Hz - 200Hz	Shell 20Hz - 200Hz	Shell 20Hz - 200Hz	Shell 20Hz - 200Hz
Residual output noise - main outputs	35Hz - 1kHz Q=0.6-2.5	35Hz - 1kHz Q=1 or 2	35Hz - 1kHz Q=1 or 2	35Hz - 1kHz Q=1 or 2	35Hz - 1kHz Q=1.8	35Hz - 1kHz Q=1.8	35Hz - 1kHz Q=1.8
Main Mix noise (nothing routed)	500Hz - 15kHz Q=0.6-2.5	500Hz - 15kHz Q=1 or 2	500Hz - 15kHz Q=1 or 2	500Hz - 15kHz Q=1 or 2	500Hz - 15kHz Q=2	500Hz - 15kHz Q=2	500Hz - 15kHz Q=1.8
Main Mix noise (24 channels routed)	Shell 2kHz - 20kHz	Shell 2kHz - 20kHz	Shell 2kHz - 20kHz	Shell 2kHz - 20kHz	Shell 12kHz	Shell 12kHz	Shell 12kHz
CONNECTION IMPEDANCES							
Mic Inputs	60Hz, 250Hz, 2.5kHz, 12kHz Q=1.8	60Hz, 250Hz, 2.5kHz, 12kHz Q=1.8	60Hz, 250Hz, 2.5kHz, 12kHz Q=1.8	60Hz, 250Hz, 2.5kHz, 12kHz Q=1.8	60Hz, 250Hz, 2.5kHz, 12kHz Q=1.8	60Hz, 250Hz, 2.5kHz, 12kHz Q=1.8	60Hz, 250Hz, 2.5kHz, 12kHz Q=1.8
Line Inputs	Swept 20Hz - 400Hz	Swept 20Hz - 400Hz	Swept 20Hz - 400Hz	Swept Off - 400Hz	Swept Off - 400Hz	Swept Off - 400Hz	Switch 100Hz
Outputs	OVU = 0dBu	OVU = 0dBu	OVU = 0dBu	OVU = +4dBu	OVU = +4dBu	OVU = +4dBu	OVU = +4dBu
EQUALISATION							
Gain (each band)	5dB before clipping	5dB before clipping	5dB before clipping	5dB before clipping	5dB before clipping	5dB before clipping	5dB before clipping
Mono Channel Low Frequency							
Mono Channel Low Mid Frequency							
Mono Channel High Mid Frequency							
Mono Channel High Frequency							
Stereo Channel Frequencies							
Filter (mono input)							
METERING							
Reading referred to Main outputs							
Peak indication threshold							
SYSTEM							
Lamp connectors	up to 4 x 4pin XLR-F	up to 3 x 4pin XLR-F	3 x 4pin XLR-F	2 x 4pin XLR-F	2 x 4pin XLR-F	2 x 4pin XLR-F	up to 2 x 4pin XLR-F
Power supply	RPS14 or MPS14	RPS14 or MPS14	RPS11	RPS11	RPS11	RPS11	Internal (16, 24, 32)